

Innovated for Point-Of-Care

# myvet CT D



Clarity



Seamless



Growth

## VETERINARY DENTAL CT SYSTEM

Acquire High Quality CT Images in Specific Area

Streamlining Diagnostics at the Point of Care

High-Quality Precise Imaging at a Lower Cost

# SITE-SPECIFIC DIAGNOSTIC CAPABILITIES

## High-Resolution CT Scanning for Dental, Extremities and Exotic Cases

MyVet CT D incorporates CMOS technology, enabling specific area scanning that is well-suited for dentistry, extremities, and exotic animals. The integration of a CMOS sensor further enhances the clarity and detail of the captured images with a high-resolution slice thickness of 0.1mm, facilitating accurate diagnosis and treatment planning.

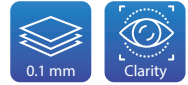

- Diagnose tooth root abscesses where x-ray is inconclusive
- Evaluate oral tumors located deep within tissues of the mouth or throat
- Evaluate complex fracture and joint abnormalities of the extremities
- Advanced imaging for exotic animals

## PRECISE AND ACCURATE DIAGNOSIS

### Powerful 3D Visualization and Tools

The software offers advanced features that allow for precise localization of specific parts within the 3D volume image, facilitating exploration of the area using slice images through the utilization of the 3D explore tool. It also offers distortion-free Multiplanar Reconstruction (MPR), ensuring accurate and precise visualization of anatomical structures in alternative planes.

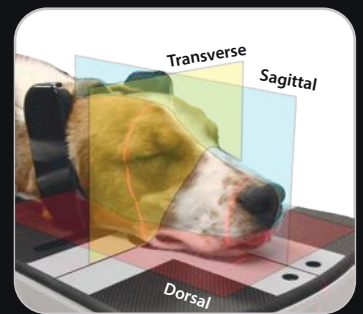
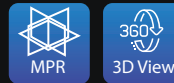

- Small animal dental specific preset technique
- Enlarge the diagnosis area by stitching multiple parts
- Isolate a specific pulp area and obtain detail results by endodontic visualization tool
- Select a specific area of interest from the 3D volume image and explore the area with slice images to the spot using 3D explore tool

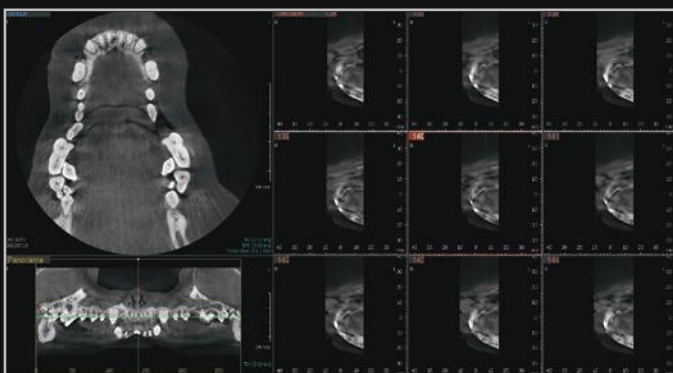

Canine, multi-section view



Feline, 3D and MPR

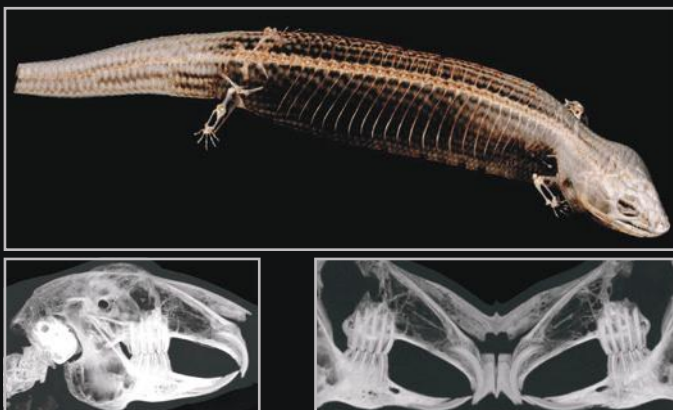

Exotic, 3D view, sagittal plane and panoramic View

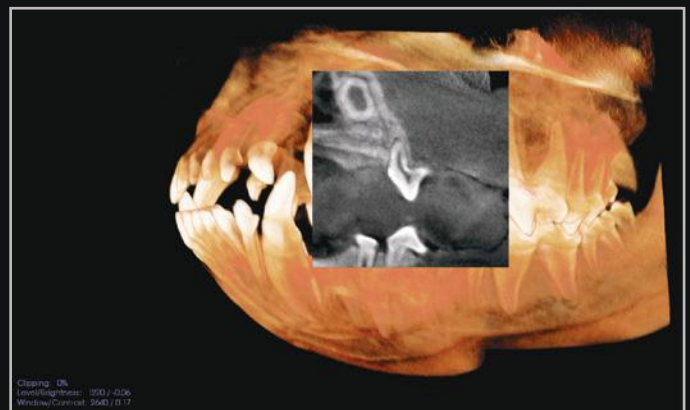

Canine, 3D view with explorer tool

# POINT-OF-CARE MOBILE SCANNING

## Easy, Quick and Accurate Patient Positioning

MyVet CT D features a space-efficient and integrated design with a touch screen monitor, fast scanning capabilities, and mobility for convenient scanning near treatment or surgical sites. It also includes a table bed, laser beam guide for positioning, and an optional extension table for patient comfort and precise imaging. Streamlining the diagnostic process allows for immediate and efficient imaging at the point of care.



**22 inch touch screen monitor**  
 » Immediate access to scan controls and  
 » Fast visualization of imaging outcomes

**Laser guide beam**  
 » Accurate positioning and reduced sedation time

**Headrest**  
 » Adjustable to ensure optimal alignment  
 » Removable for a larger patient

**Optional extension bed**  
 » For a larger patient

**Carbon fiber bed**  
 » Quick transitions from scan to treatment

**True mobility**  
 » Enables scan next to the site of treatment or surgery

**Scanning Time**  
 27 SEC

**Laser beam guidance**

**Adjustable headrest**

**Carbon fiber bed**

## As Simple as 5 Clicks for Scanning

- 1 Select Species**
- 2 Select Image Option**
- 3 Select Parameters**
- 4 Select Confirm**
- 5 Select Ready**

Confirm Positioning

Ready





# COST-EFFECTIVE PRECISION IMAGING

## Advanced Diagnostics with Energy Efficiency and Reduced Expenses

MyVet CTD offers a cost-effective solution compared to other CT systems, while still providing advanced diagnostic outcomes for site-specific examinations. In addition to its affordability, this system presents advantages such as lower operational costs, reduced maintenance requirements, and energy efficiency, delivering significant benefits to veterinary practices.

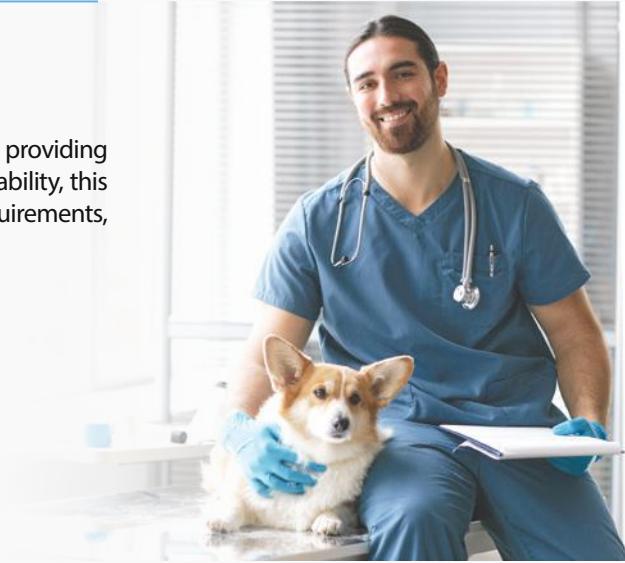

## SPECIFICATIONS

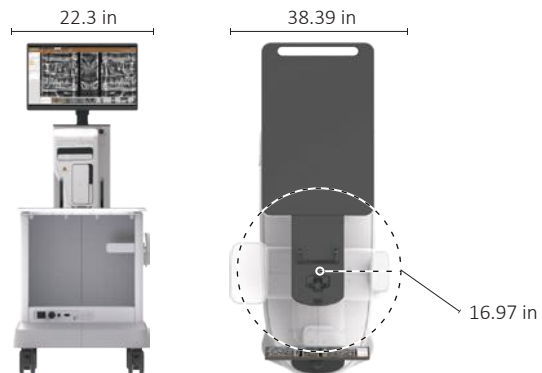
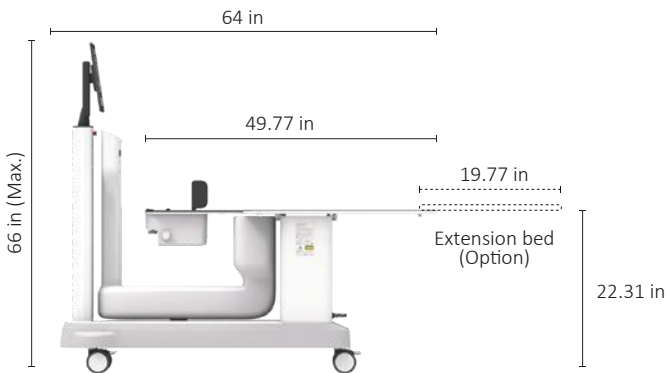

Item	Description
Weight	308.6 Lbs (140 Kg)
Dimensions (L x W x H)	64 x 38.39 x 66 (Max.) in (1627 x 975 x 1676 mm)
Radius of rotator rotation	16.97 in (431 mm)
Extension bed (Option)	19.77 x 21.42 x 0.28 in (502 x 544 x 7 mm)

Item	Specification
Line Voltage (Input)	120 - 240 Vac
Power rating	1.6 kVA
Installation type	Integrated system

\* The dimensions are dimensions in operation.